

OPERATION MANUAL

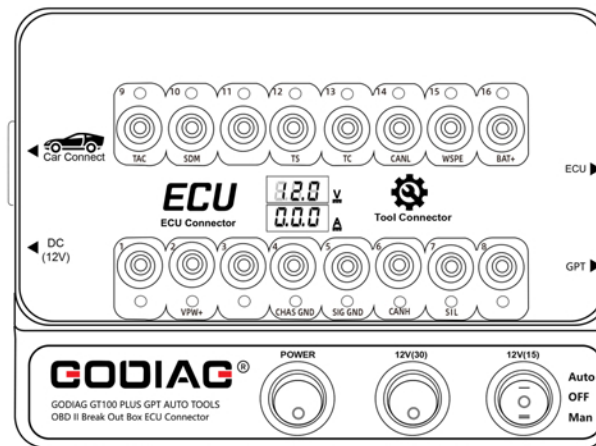

www.godiag.com



ABOUT
US

Shenzhen Sinoy Technology Co.,Ltd

- 🌐 www.godiag.com
- 📍 Room 301, Building 1, Bada Industrial Park, No. 9 Tangkeng Road, Liuyue Community, Henggang Street, Longgang District, Shenzhen
- ☎ +86 18813687743
- ✉ Sales@GoDiag.com

AUTO TOOLS
OBD II Break Out Box
ECU Connector

GT100 PLUS GPT

1. Document Statements

Please read the following instructions carefully:

The manual may help you learn about how to use GODIAG GT100 PLUS GPT ENET DOIP 24V-12V AUTO TOOLS OBD II Break Out Box ECU Connector in a faster pace. Please observe your local national laws and regulations. In case of illegal use of GODIAG equipment, the user shall bear all risks and the company shall not assume any liability.

GODIAG GT100 PLUS GPT ENET DOIP 24V-12V AUTO TOOLS OBD II Break Out Box ECU Connector Operation Manual is compiled by GODIAG. No company or individual may copy or backup this manual in any form (electronic seal, mechanical, photocopy, recording, picture or other forms) without the written consent of GODIAG. The document shall not be used for commercial purposes.

2. Trademark Copyrights

GODIAG has been registered as a trademark in China and several overseas countries.

Disclaimer and limitation of liability

All information, specifications and images included in the manual are latest information as of the date of publication. GODIAG reserves the right to make changes without prior notice. The contents in the manual have been carefully reviewed, but no warranty is given as to its completeness and accuracy of contents (including specifications, functions and images). GODIAG does not bear any direct or indirect compensation for damages or economic damages.

Notes: before operating or maintaining the equipment, please read the manual carefully, especially the safety precautions.

3. Service and Technical Support

www.godiag.com +86 18813687743 Sales@GoDiag.com

4. Safety Precautions

In order to protect the safety of yourself and others and prevent damaging the equipment and vehicles, please read the safety precautions carefully.

Since various programs, tools, parts and techniques are used for the vehicle maintenance and different operators may have different operations, due to various kinds of diagnostics compliers, the manual cannot predict every situation and provide related safety suggestions.

Vehicle service technicians are in charge of fully learning about the system under tests, and applying appropriate repairing approaches and testing programs.

When conducting tests, it's necessary to apply proper operations to avoid personal safety risks to yourself and other people inside the working area and prevent damages to the equipment in use or vehicles under tests.

Before starting to use the equipment, please refer to and observe the safety information provided by the vehicle or equipment manufacturer and applicable testing programs. Please use the equipment according to the Operation Manual, read, understand, and observe all safety information and instructions included in this manual.

Please at least observe the following safety precautions working at the vehicle:

- ◆ Please work at a safe environment where it's essential to keep the working area ventilated since the vehicle exhaust is harmful to human bodies.
- ◆ Wear goggles that meet the ANSI standard.
- ◆ Set the gear to P (auto) or N (manual) and guarantee the parking brake is enabled (hand brake pulled).
- ◆ Make sure your clothes, hair, hands, and tools stay away from the operating engine parts or hot engine parts.
- ◆ Place bricks before each wheel to prevent the vehicle from moving accidentally.
- ◆ The vehicle must be attended during testing and operating.
- ◆ Pay special attention when working around the ignition coil, distributor cap, ignition wire, and ignition plug for that these parts can generate dangerous voltages.
- ◆ Make sure fire extinguishers suitable for the gas/chemicals/are electrical provided at the site.
- ◆ Do not plug or unplug the equipment when the ignition switch is on or the engine is working.
- ◆ Keep the equipment dry, clean, and avoid touching oil, water or grease. Use a clean cloth to clean the equipment.
- ◆ Do not operate the diagnostic equipment during driving to avoid accidents owing to the distraction.
- ◆ Please refer to the maintenance manual when maintaining the vehicle and operate strictly according to the precautions, otherwise it may cause human injury or damages to the diagnostic equipment.
- ◆ Do not place the diagnostic equipment onto the distributor of the vehicle for that strong EMI may damage the equipment.

5. Contents

1. Document Statements.....	01
2. Trademark Copyrights	01
3. Service and Technical Support	01
4. Safety Precautions	01
5. Contents	03
6. Feature Overview	04
7. Outlook	05
8. Functions and How to Use	06
9. GT100 PLUS GPT Package List	27
10. Product Specifications	28
11. Warranty	29

6. Feature Overview

GODIAG GT100 PLUS GPT is a testing platform for OBDII protocol communication detection and ECU maintenance / diagnosis / programming / coding. GT100 PLUS has a voltage and current display which is convenient for maintenance engineers to judge the GPT current working status of ECU.

It can convert the car OBD2 interface into 16 pin for signal detection. It can be connected to the single modules or multiple modules of the vehicle. It can also be connected with any diagnostic tool to tell whether the car communication is good or not.

It supports the 24v to 12v voltage conversion, DOIP-ENET communication and GPT to read and write ECU data. It can also supply power to the car when you change the battery to avoid the vehicle control module data being lost, automatically locked, the key remote control fails and the fault light turns on.

See the detailed functions as below:

- GT100 PLUS GPT Read and Write ECU with GPT
- GT100 PLUS GPT OBDII Protocol Detector and Protocol Communication Diagnosis
- GT100 PLUS GPT Support DOIP-ENET Diagnostics
- GT100 PLUS GPT Convert 24V to 12V
- GT100 PLUS GPT OBDII Protocol Detector and Protocol Communication Diagnosis
- GT100 PLUS GPT Short circuit to forcibly activate the instrument and immobilizer
- GT100 PLUS GPT Voltage / Current Value Display
- GT100 PLUS GPT OBDII Display custom CAN protocol communication
- GT100 PLUS GPT ECU Connection
- GT100 PLUS GPT Expanded Connection
- GT100 PLUS GPT OBD1 Diagnostic Interface Converted to Standard OBD2
- GT100 PLUS GPT Multi-ECU Connection Mode
- GT100 PLUS GPT Extension cable Function
- GT100 PLUS GPT Power the Car When Replacing the Battery
- GT100 PLUS GPT Optional dedicated Adapter
- GT100 PLUS GPT Work with CAS1/CAS2 Mech-Key Test Platform
- GT100 PLUS GPT Work with CAS2 CAS3 SER Semi Smart Test Platform
- GT100 PLUS GPT Work with CAS4/CAS4 + Programming Test Platform
- GT100 PLUS GPT Work with FEM/BDC Programming Test Platform

7. Outlook

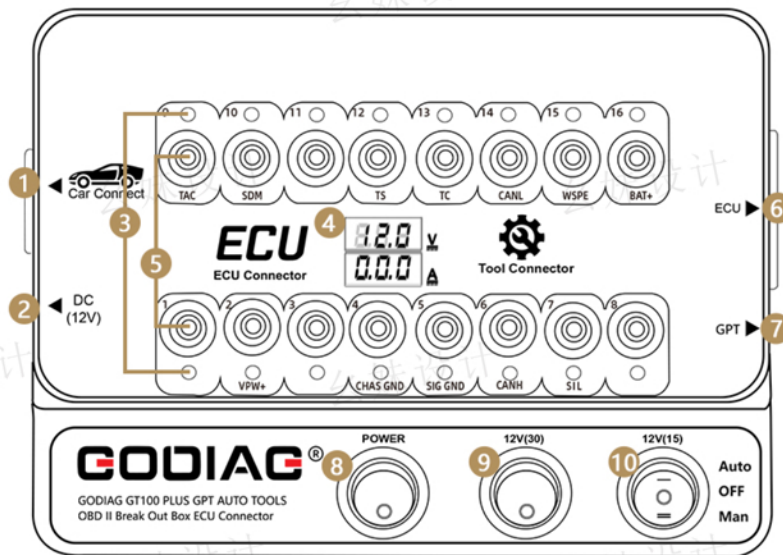

- ① OBD2-DB15 diagnostic main cable
- ② DC12V interface
- ③ Indicators
- ④ Working voltage and current value display
- ⑤ Banana plug interface
- ⑥ DB25 color jumper ECU dedicated interface
- ⑦ GPT interface
- ⑧ Power switch
- ⑨ 12V (30) power switch.
- ⑩ 12V (15) power switch

8. Functions and How to Use

1.) Cooperate with ECU reading and writing equipment to read and write ECU through GPT BOOT method

- Support GPT to read and write data without disassembling the ECU.
- Support OBD2 BENCH [CAN bus & K-Line]
- Support GPT BOOT CNF1

How to Operate:

① Use the GPT BOOT adapter cable to connect the ECU according to the corresponding connection definition. [The ECU connection definition can be found on the Internet, or refer to the ECU interface definition diagram of other ECU read/write devices for connection.]

② The GT100 PLUS GPT host 12V (15) switch can be switched to the "Auto" position for PCMflash ECU read/write devices. When the PCMflash ECU device is connected, it will automatically control the power supply and GPT communication via the L-Line, thus stably reading and writing ECU data. Other devices can only use the "Man" position to control the power supply.

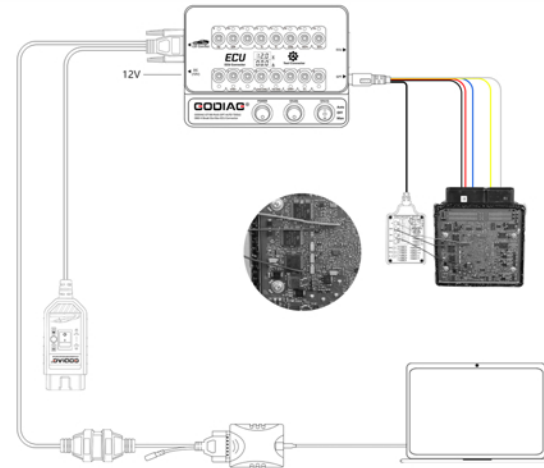
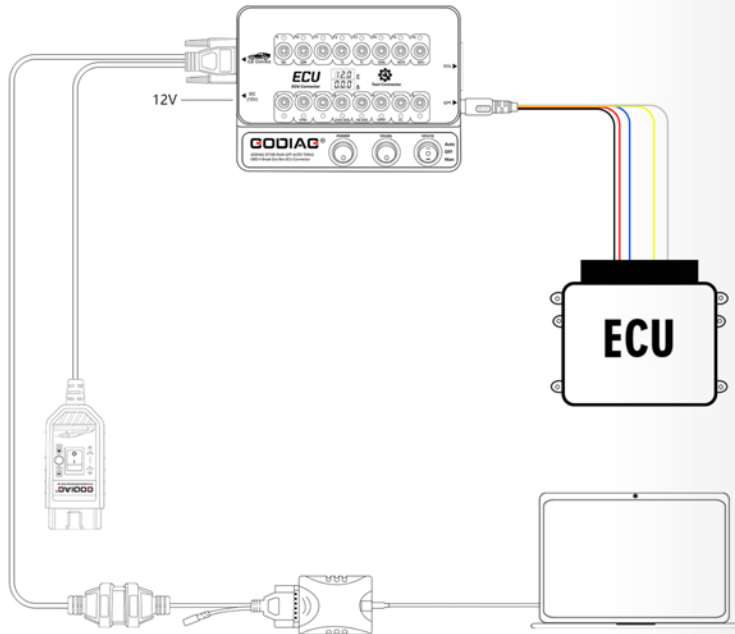

2.) OBDII Protocol Detector and Protocol Communication Determination

Standard OBDII interface protocol
Support OBD2 BENCH full protocols

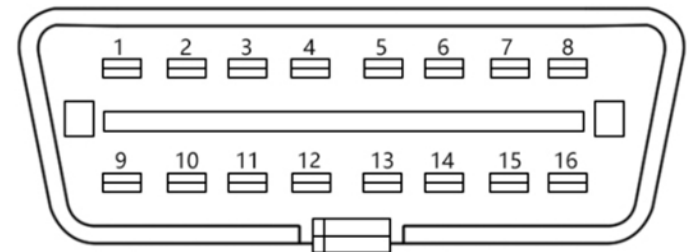

Indicator Light Meaning

1. Manufacture custom	9. Manufacture custom
2. SJE1850 wire <bus+>	10. SJE1850 wire<bus->
3. Manufacture custom	11. Manufacture custom
4. Power grounding	12. Manufacture custom
5. Signal grounding	13. Manufacture custom
6. SAEJ2284 <CAN> high	14. SAEJ2284 <CAN> low
7. ISO9141-2 & iso, DIS4230-4K wire	15. ISO9141-2 & ISO/DIS 4230-4L wire
8. Manufacture custom	16. Car battery positive

Car OBDII Port

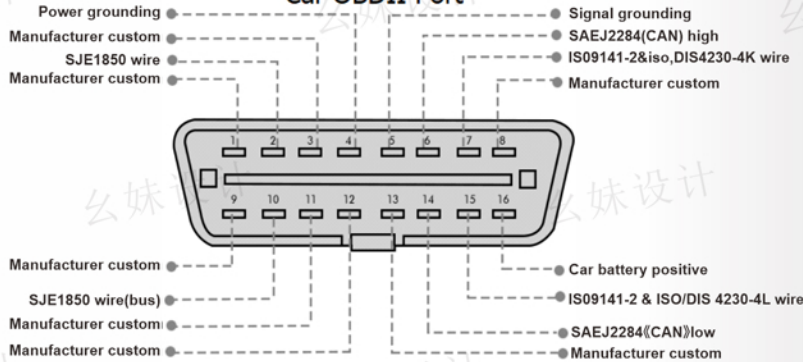

GT100+DB25 Port

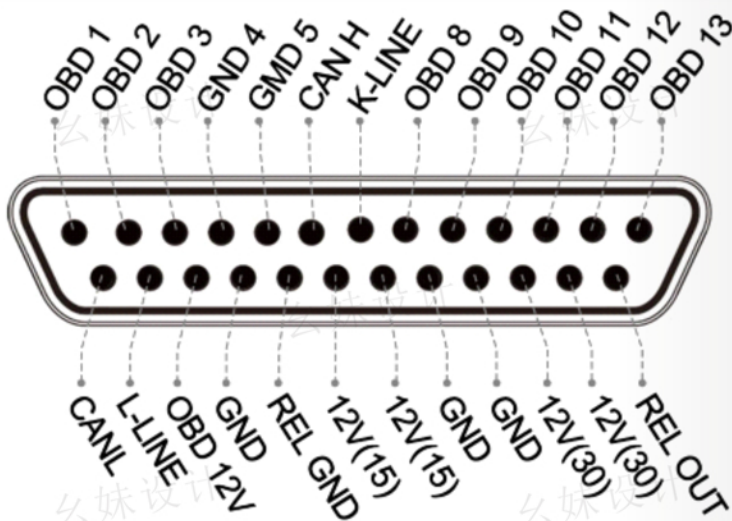

DB25 Color jumper Cable

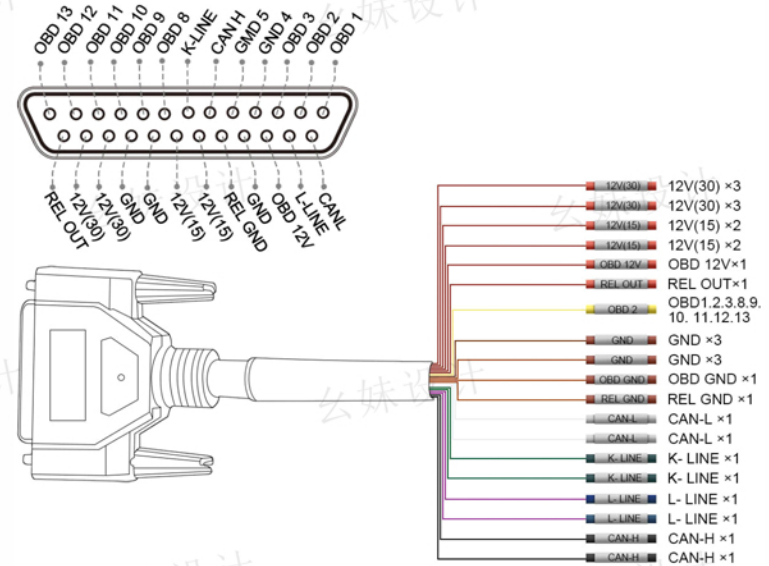

Tips on Using DB25 Color Jumper Cable:

1. 12V (30) defined as car positive (+)
2. 12V (15) defined as car ignition with power supply
3. OBD 12V directly connected to the vehicle OBDII diagnostic port 12V
4. OBD 1.2.3.8.9.10.11.12.13 are correspondingly connected to the 1.2.3.8.9.11.10.12.13 pin port.
5. Once REL GND and GND are connected, REL OUT outputs 12V vehicle battery positive electricity.
6. K-LINE L-LINE are correspondingly connected to the 7.K-LINE and 15. L-LINE port.
7. CAN-H and CAN-L are correspondingly connected to the 6.CAN-H and 14.CAN-L port.

◎ By connecting the vehicle and the diagnostic tool via OBDII, Godiag GT100 PLUS GPT can check whether the communication of the vehicle OBDII diagnostic port is normal.

◎ To monitor and display in real-time the voltage of vehicle OBDII interface. If the voltage is lower than 11V, please stop diagnosing and programming, otherwise the car will fail to start, the data is lost, the module is locked etc because of low battery.

3.) Support DOIP-ENET Diagnostics

Support DOIP-ENET communication

Support diagnostic programming and coding for BMW Benz, Volkswagen, Audi and other vehicles that support DOIP protocol. [no software is provided.]

It can be used for diagnostic programming and coding of Land Rover, VOLVO, and Geely vehicles that support DOIP communication. [no software is provided.]

How to Operate:

① Connect the male end of the main cable to the truck's diagnostic port and turn the 24v-12v converter switch to the OFF position.

② Press the ENET switch and the network interface communication indicator light flashes.

③ Through computer software, you can diagnose and program the corresponding vehicle that supports DOIP-ENET communication.

Note: Do not connect to the GT100 PLUS GPT host, as the GT100 PLUS GPT host will affect DOIP-ENET communication.

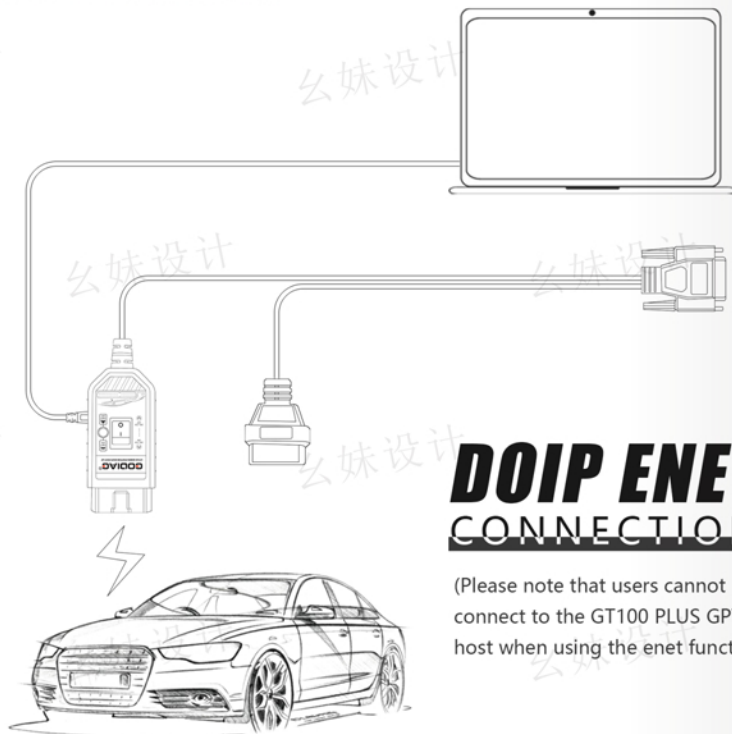

(Please note that users cannot connect to the GT100 PLUS GPT host when using the enet function.)

4.) 24V to 12V Voltage Conversion

Convert the 24v voltage of the diagnostic interface of heavy trucks, light trucks, pickups, etc. into 12.5v voltage that can be used by diagnostic equipment.

How to Operate:

① Connect the male end of the main cable to the truck's diagnostic port and turn the 24v-12v converter switch to the ON position.

② The output voltage of the GT100 PLUS GPT host and the main cable female end is 12.5V, which can be used to connect to a LAUNCH or other 12V diagnostic equipments.

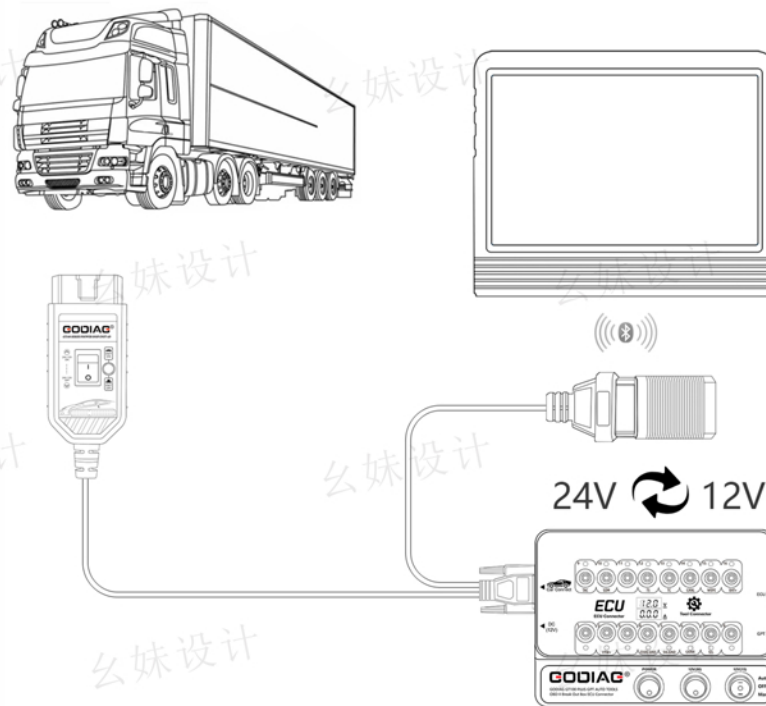

5.) Connect with Airbag ECU

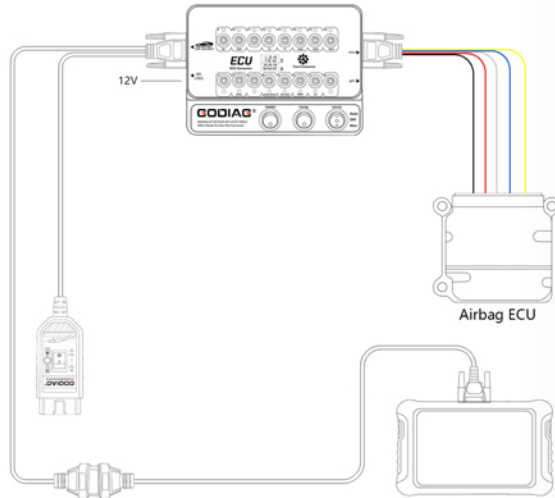

6.) Used to check whether the diagnostic / programming / coding tool can send communication signals.

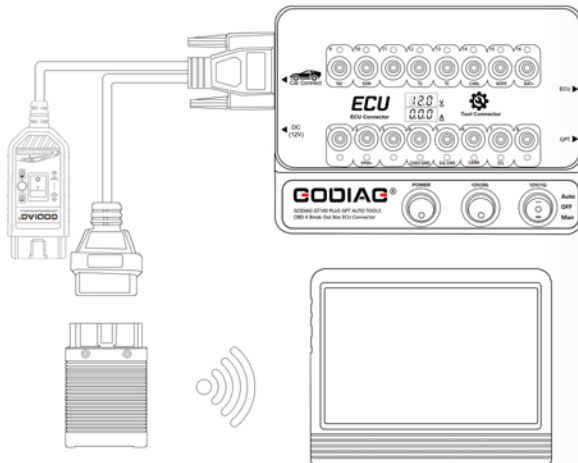

① Connect the diagnostic / programming / coding tool to the OBD2 port of GT100 PLUS GPT. (Do not connect it to the vehicle)

② Select the vehicle model and functions to operate.

③ If the device can send the communication signals, the corresponding protocol indicators on the GT100 PLUS GPT will be ON or blink. If the device can't send the communication signals, there will be no indicator light on, it means the device has a connection problem or is damaged.

7.) Test the communication status between the code reader and the vehicle protocol.

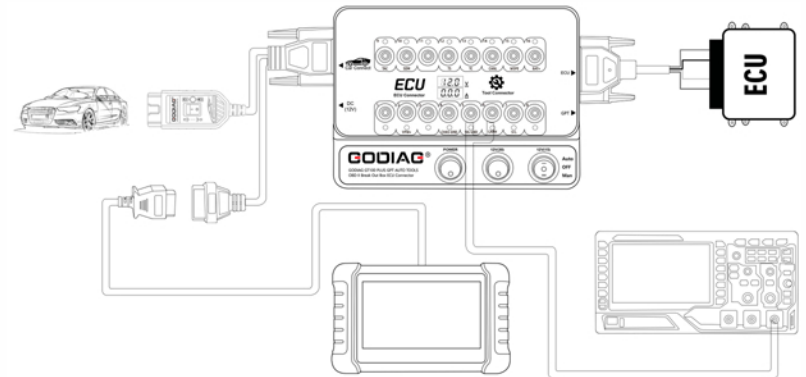

① GT100 PLUS GPT is connected to the vehicle OBD2 port.

② Start the Power switch, and GT100 PLUS GPT will display the current accumulator voltage. (If no voltage is displayed, please check the vehicle diagnostic interface and the cable. If the voltage is lower than 10V, please do not start the vehicle or go ahead for function operation, Please charge the car with a car charger.)

③ Connect the diagnostics / programming / coding tool well. When it communicates with the vehicle, the corresponding protocol indicators on the GT100 PLUS GPT equipment will be lit up or blink. It's convenient for users to observe which protocol is under use by the vehicle module and the status of the communication.

8.) GT100 PLUS GPT program key for VW, Porsche, Mitsubishi etc with all keys lost - activate the instrument or immobilizer module.

A. To program VW 4th generation / 5th generation Lost all keys (for example: new A6L Touareg A4 Q5 A7), please use GT100 PLUS GPT to short-circuit banana connector PIN 16---PIN 1 to lit up the dashboard, aft that use the key programmer tool to connect with the female adapter of GT100 PLUS GPT for data collection. Some vehicle dashboards won't be lit up, but data can also be collected, for example: A6L Q7.

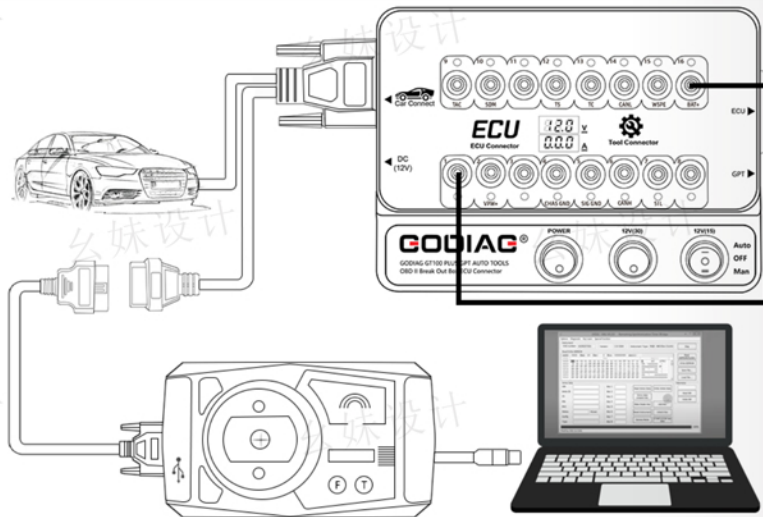

B. To replace the engine ECU of Toyota or to use some key programmer to program Toyota when all keys lost, it needs to short-circuit PIN13-PIN4

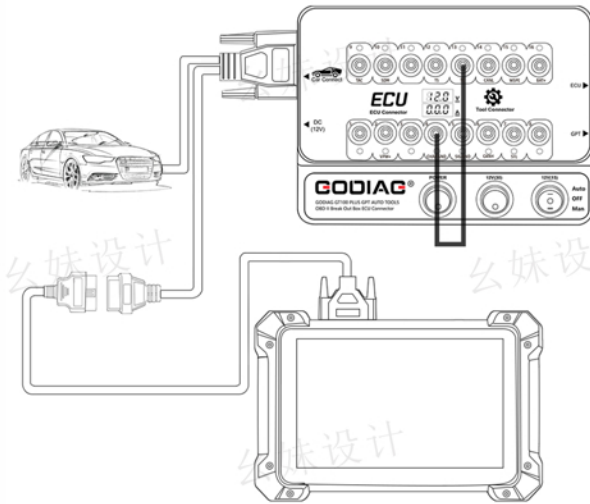

C. To program Mitsubishi key with all keys lost or to set OBDII when all remote key lost, please short-circuit PIN1-PIN4.

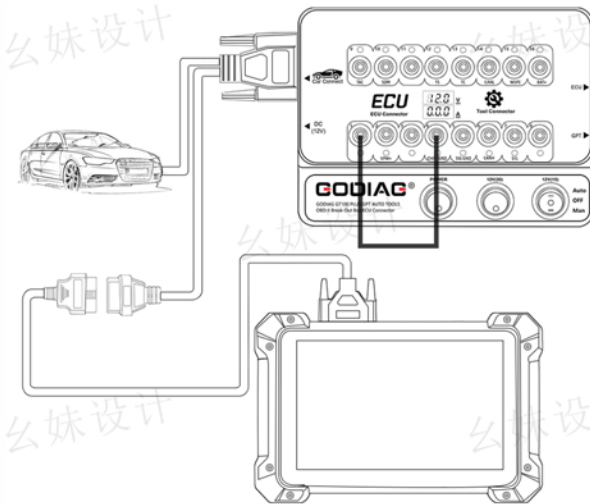

D. To program Porsche Cayenne transponder or remote all keys lost, please short circuit PIN3-PIN7.

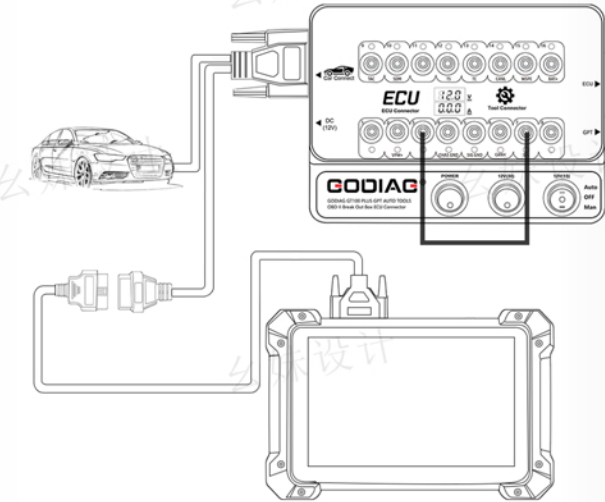

9.) Voltage and Current Value Display function

On bench connect the ECU module by using the banana connector or DB25 dedicated ECU interface, and Godiag GT100 PLUS GPT will display the voltage / current value.

The user can intuitively see the current status of the ECU. There is no current display or The actual displayed current is inconsistent with the engineer's expected current, then you can immediately check whether the wiring is wrong, if the wiring is correct, he can judge that the ECU may be broken, so there is no need to perform diagnostic communication and can directly repair the ECU.

If it shows too much current, then you can also determine if the cable is wrongly connected or the ECU is broken.

10.) GT100 PLUS GPT Pin 1, 9, 3, 11 12, 13, 8 [corresponding to the yellow banana connector on the machine], these non-standard obd2 protocol interface may display CAN BUS or K-Line communication protocol. GT100 can only display K- Line PWM VPW+ KWP 2000 protocol. GT100 PLUS GPT will display CANBUS K-Line PWM VPW+ KWP 2000 protocol communication.

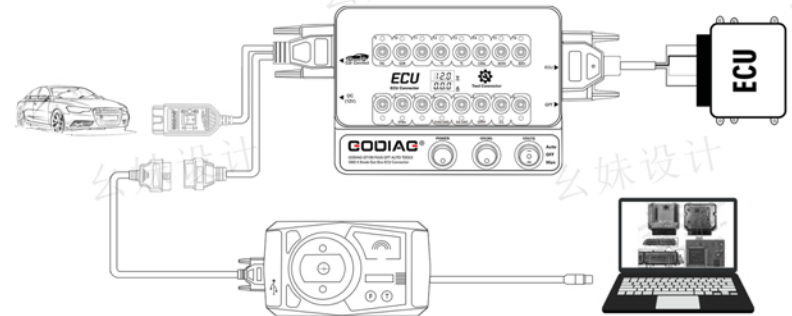

11.) Quickly communicate with a single ECU on bench by connecting with the ECU diagnostic / programming tool. [Which allow the engineers or technicians to complete the job on bench, also keep away the risk of data loss in other modules when directly testing on the vehicle.]

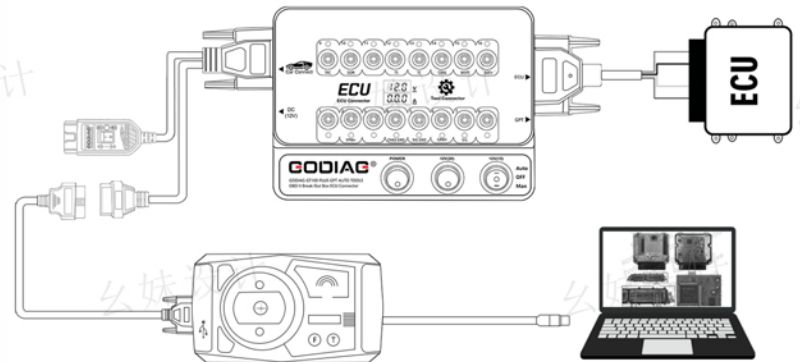

How to Operate:

- ① Connect GT100 PLUS GPT and the dedicated ECU color jumper.
- ② Connect the ECU which needs to diagnose or program by following the definition of ECU connecting.
- ③ Connect the 12V DC power adapter.
- ④ Start the Power switch, and GT100 PLUS GPT will display the current working voltage of the power adapter.
- ⑤ By connecting well the diagnostic / programming / coding tool, GT100 PLUS GPT protocol indicator will turn on or blink to indicate which protocol of the car module and the communication status.

12.) Multiple vehicle ECU module connecting. [It's aimed at solving the problem of engineers and technicians who need to connect multiple ECU during programming a module, such as connecting to multiple ECU modules for key programming]

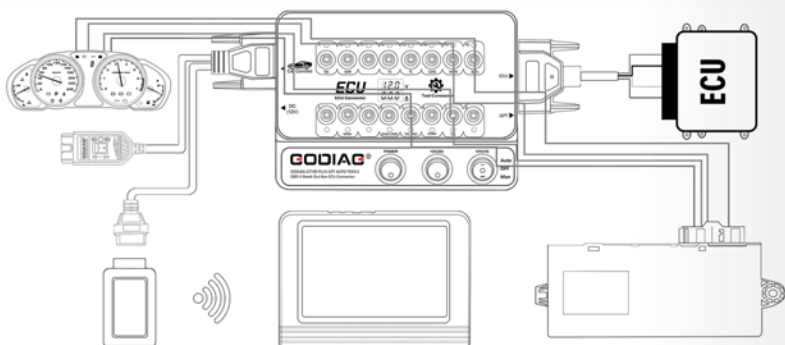

Multiple ECU Module Connection Operation Steps:

- ① Connect GT100 PLUS GPT and Colorful Jumper Cable DB25. Insert the DB25 jumper into the banana plug, tighten the screw, and then insert it into the corresponding port of GT100 PLUS GPT .
- ② Connect the ECU which needs to diagnose or program by following the definition of ECU connecting.
- ③ Connect the 12V DC power adapter.
- ④ Start the Power switch, and GT100 PLUS GPT will display the current working voltage of the power adapter.
- ⑤ When there is a good communicating between the car and the diagnostic / programming / coding tool, GT100 PLUS GPT protocol indicator will turn on or blink to indicate which protocol of the car module and the communication status.

13.) Replace the Auxiliary Power Supply for the Battery - uninterruptible power supply connecting mode. [Since there's failure or missing antitheft remote control data of some vehicles when the battery is dismantled, the auxiliary power supply aims at supplying power to the vehicle through GT100 PLUS GPT before replacing the battery to sustain the power supply to the vehicle. It guarantees the vehicle ECU is power connected during replacement of the battery.]

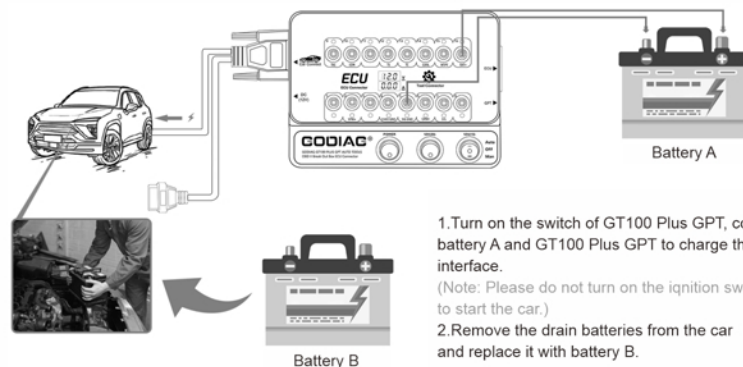

1. Turn on the switch of GT100 Plus GPT, connect battery A and GT100 Plus GPT to charge the OBD2 interface.
(Note: Please do not turn on the ignition switch to start the car.)
2. Remove the drain batteries from the car and replace it with battery B.

Uninterruptible Power Supply Connecting Mode Operation Steps:

- ① Prepare a spare battery "A" and a new battery "B" to be installed.
- ② Connect to NO.16 /4 /5 holes of Godiag GT100 PLUS GPT and the OBD2 diagnostic port of the car, and connect to the spare battery "A".
- ③ Switch on GT100 PLUS GPT Power.
- ④ Connect GT100 PLUS GPT diagnostic cable to the OBD2 port of the vehicle. [Notes: do not turn on the ignition or start the vehicle.]
- ⑤ Install the new battery "B"

14.) The OBD2 cable of GT100 PLUS GPT is as long as 1.4 meters, which will solve the problem that the diagnostic tool cable is not long enough or the vehicle diagnostic port is too narrow to connect. Please connect GT100 PLUS GPT first, turn on the power switch and you will see the voltage on the screen which can tell whether the power supply of the vehicle is normal. [Which keep away the risk of burning out the diagnostic & programming tool due to the modified vehicle OBD2 port]

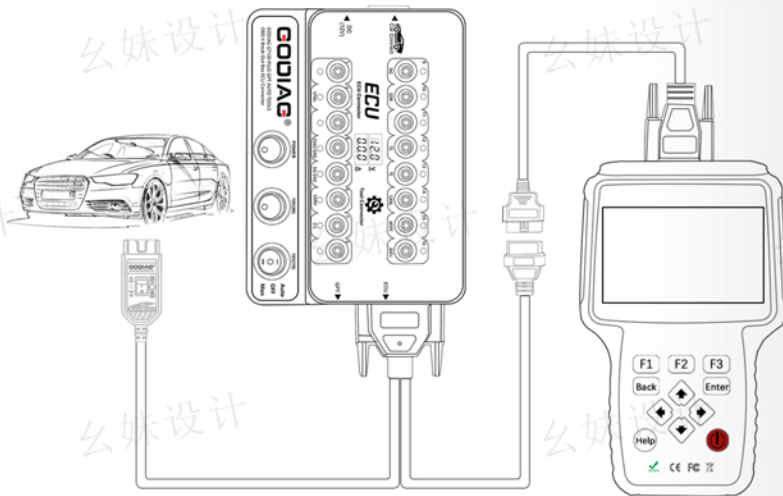

Operation Steps:

- ① Connect GT100 PLUS GPT OBD2 to the OBD2 port of the vehicle.
- ② Switch on GT100 PLUS GPT Power. (If no voltage is displayed, please check the vehicle diagnostic port and the cable. If the voltage is lower than 10V, please do not start the vehicle or operate. Please charge the accumulator with a car charger first)
- ③ The other OBD2 port of GT100 PLUS GPT is connected to the diagnostic tool.
- ④ When there is a good communicating between the car and the diagnostic / programming / coding tool, GT100 PLUS GPT protocol indicator will turn on or blink to indicate which protocol of the car module and the communication status.

15.) For old OBD1 vehicles or special diagnostic port, please connect GT100 PLUS GPT through the banana plug and DB25 jumper. The OBD1 diagnostic port or special diagnostic port can be transferred to the standard OBD2 diagnostic port.

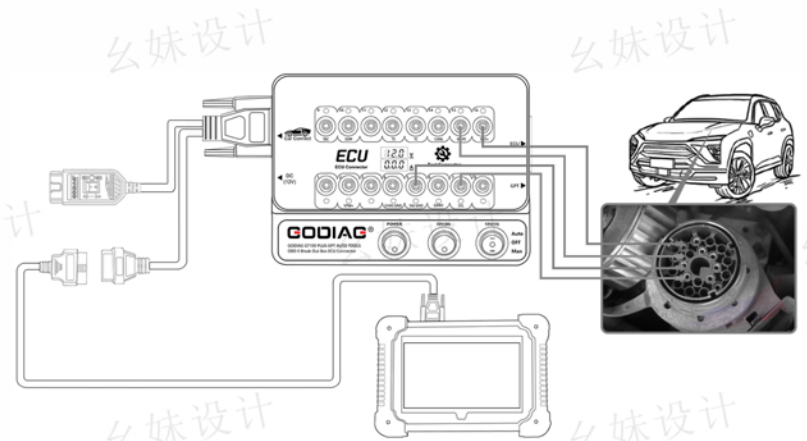

- ① Insert the DB25 jumper into the banana plug, tighten the screw.
- ② Insert the banana plug into the corresponding port of GT100 PLUS GPT by following the OBD1 protocol.
- ③ Connect the OBD2 port of GT100 PLUS GPT to the diagnostic tool.
- ④ When there is a good communicating between the car and the diagnostic / programming / coding tool, GT100 PLUS GPT protocol indicator will turn on or blink to indicate which protocol of the car module and the communication status.

16.) GT100 PLUS GPT will convert the OBD1 port of special truck to the standard OBD2 diagnostic port according to the protocol.

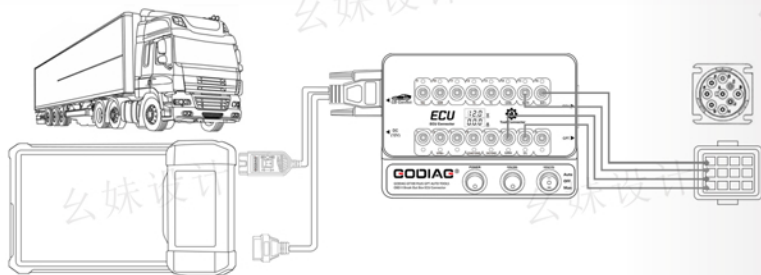

Steps:

- ① Insert the DB25 jumper into the banana plug, tighten the screw.
 - ② Insert the banana plug into the corresponding port of GT100 PLUS GPT by following the truck OBD protocol.
 - ③ Connect the OBD2 port of GT100 PLUS GPT to the diagnostic tool.
- When there is a good communicating between the car and the diagnostic / programming / coding tool, GT100 PLUS GPT protocol indicator will turn on or blink to indicate which protocol of the car module and the communication status.

17.) Work with CAS1/CAS2 Mech-Key Test Platform

How to Operate:

- ① Connect the CAS1/CAS2 Mech-Key Test Platform and the BMW CAS1/CAS2 IMMO module.
- ② Turn on the 12V (30) and 12V (15) switches.
- ③ By operating the CAS1/CAS2 Mech-Key Test Platform, you can diagnose and program the BMW CAS1/CAS2 IMMO module or perform key matching.
- ④ After matching the key, the module and key can be tested synchronously.

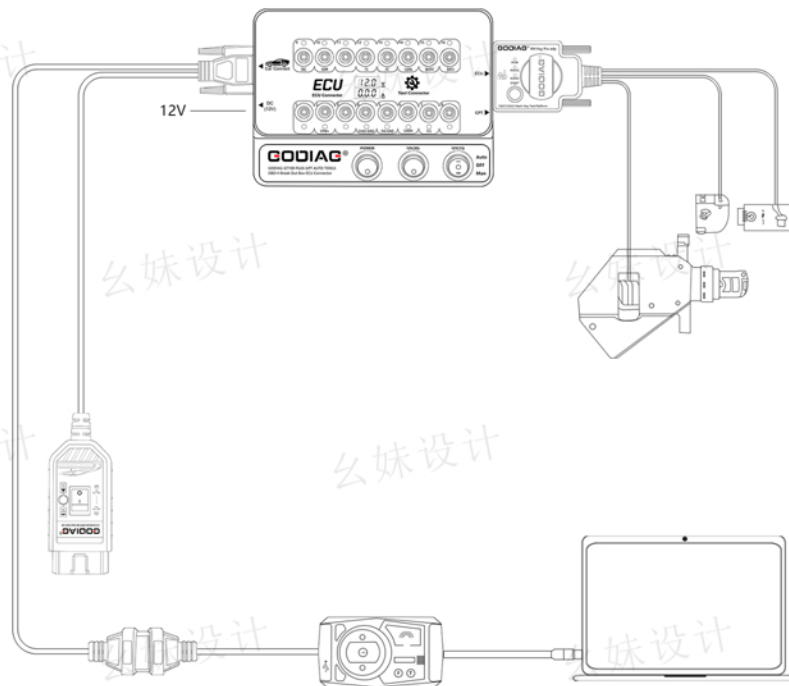

18.) Work with CAS2 CAS3 SER Semi Smart Test Platform

How to Operate:

- ① Connect the CAS2 CAS3 SER Semi Smart Test Platform and the BMW CAS2 CAS3 IMMO module.
- ② Turn on the 12V (30) and 12V (15) switches.
- ③ By operating the CAS2 CAS3 SER Semi Smart Test Platform, you can diagnose and program the BMW CAS2 CAS3 IMMO module or perform key matching.
- ④ After matching the key, the module and key can be tested synchronously.

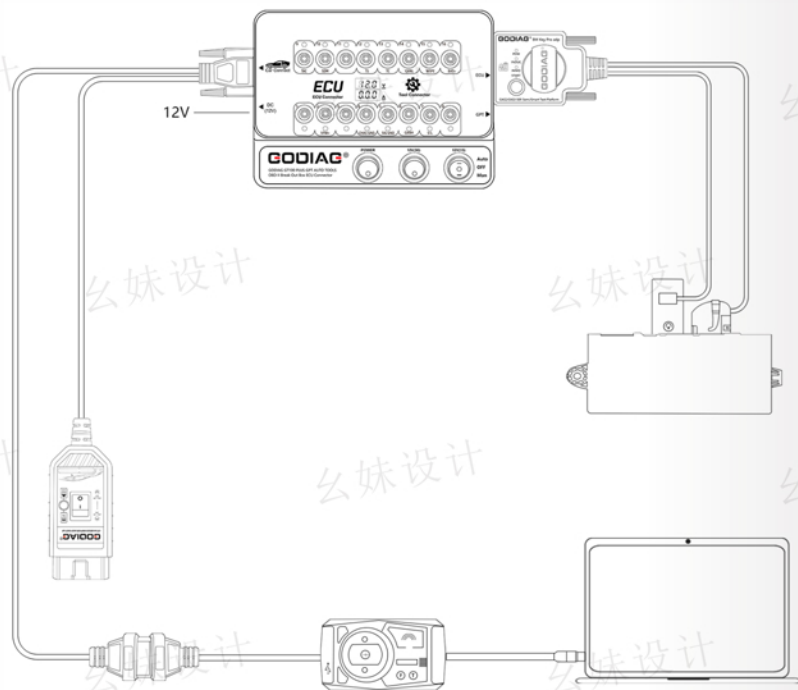

19.) For BMW-CAS4/CAS4+Programming Test Platform, it's used to test whether the programmed key works with CAS4 normally.

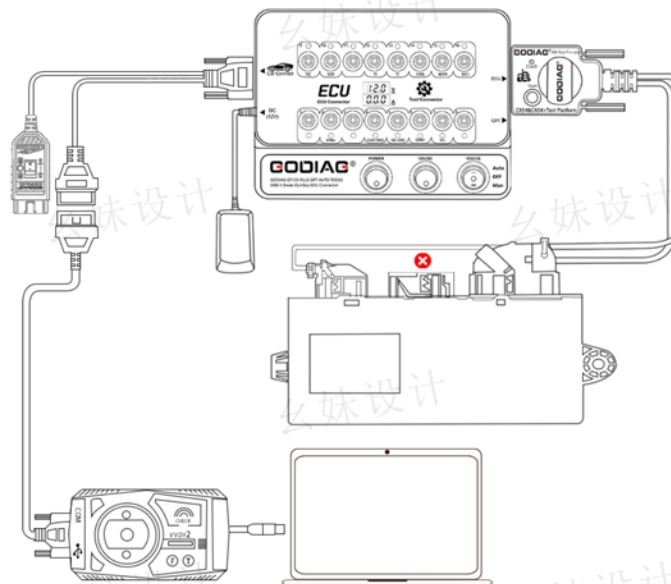

CAS4/CAS4 + Programming Test Platform Operation Steps:

- ① Connect the CAS dedicated plug to the CAS4 immobilizer module.
- ② Connect Godiag CAS4 / CAS4+ programming test platform to GT100 PLUS GPT.
- ③ Connect the OBD2 female cable of GT100 PLUS GPT to VVDI2 or the device which can read the data of CAS4.
- ④ Open the key programmer software, follow the instruction to obtain the data to complete key programming.
- ⑤ If all keys lost, please keep pressing the start switch to forcibly start CAS4 so that the key programmer can read the data of CAS4.
- ⑥ Put the programmed key into the key coil of Godiag CAS4 / CAS4+ programming test platform.
- ⑦ Press the start switch of Godiag CAS4 / CAS4+ programming test platform, if the dashboard indicator turn on, it means that the key and the CAS4 module are synchronized, otherwise, they are not synchronized.
- ⑧ Press the start switch again, and the dashboard indicator turn off.
- ⑨ Press the start switch again, wait for about 10s and GT100 PLUS GPT CAN protocol indicator turn off.

20.) For BMW FEM/BDC Programming Test Platform

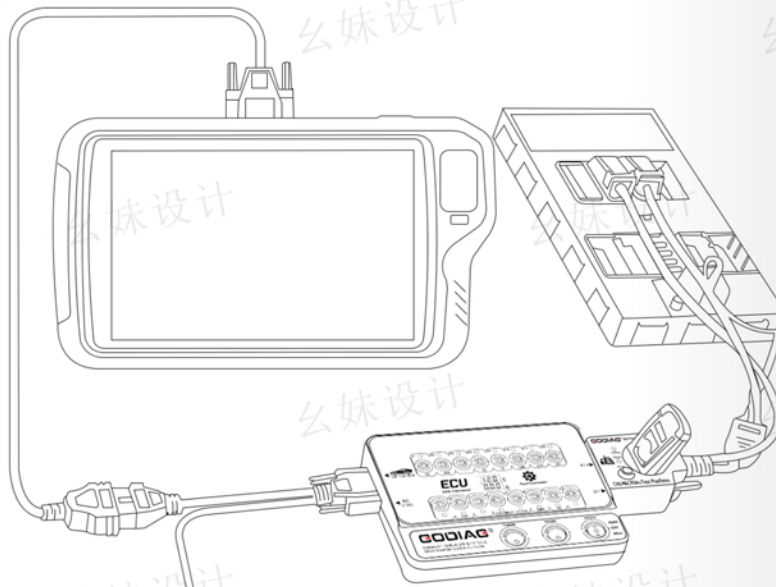

BMW FEM/BDC Programming Test Platform Operation Steps:

- ① Connect FEM/BDC dedicated plug to FEM/BDC immobilizer module.
- ② Connect GT100 PLUS GPT or Godiag OBD2-DB25 cable to Godiag FEM/BDC programming test platform.
- ③ Connect the OBD2 female cable of GT100 PLUS GPT to VVDI2/ VVDI KEY Tool plus or any other key programmer which can read data of FEM/BDC.
- ④ Open the key programmer software, follow the instruction to obtain the data to complete key programming.
- ⑤ Put the programmed key into the key coil of Godiag FEM/BDC programming test platform.
- ⑥ Press the start switch of Godiag FEM/BDC programming test platform, if the dashboard indicator turn on, it means that the key and the FEM/BDC module are synchronized, otherwise, they are not synchronized.
- ⑦ Press the start switch for more than 3s, and the dashboard indicator turn off.

21.) More connectors and dedicated modules are under development, please wait...

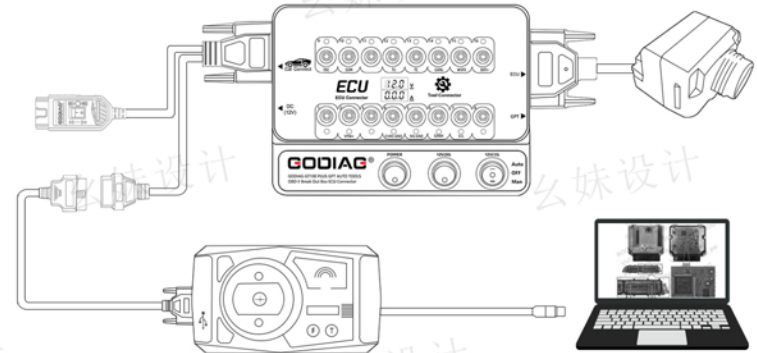

9. GT100 PLUS GPT Package List

- GT100 PLUS GPT host
- DB15-OBDII male connector - OBDII female connector
- DB25-ECU cable
- Banana plug connector
- 12V 1a power adapter
- Jumper
- CAN 120 ohm resistor
- GPT connecting cable
- Ethernet cable

10. Product Specifications

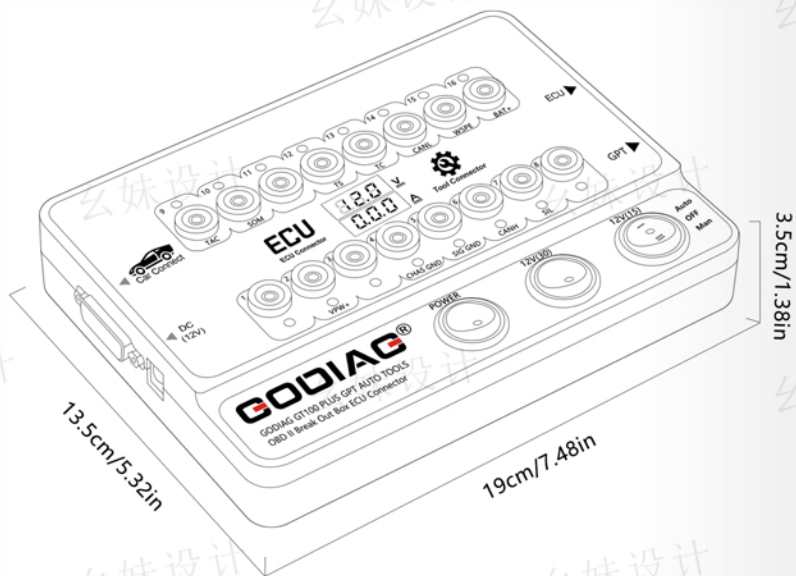

Content	Description
Diagnostic interface	OBDII 16 pin
Working voltage	DC 9V-24V
Product power	0.8W
Adapter power	Input AC100v-240v output DC12.5V 2.5A
Working temperature range	-20 to 70 °C (-4 to 158 °F)
Storage temperature range	-40 to 85 °C (-40 to 185 °F)
Product packaging size	Carton 24*18*8 CM

11. Warranty

The product has a warranty of 1 year.

Please fill in the following maintenance information for any after-sales services:

Contact name

Mailing address

Tel.

Complete problem

Proof of purchase

Send the equipment to your local distributor.

GODIAG®

Shenzhen Sinoy Technology Co.,Ltd

All rights reserved

www.godiag.com

+86 18813687743

Sales@GoDiag.com



Thank you for choosing GODIAG GT100 PLUS GPT AUTO TOOLS !